

Novo Plug-in System – The Intelligent Solution

The thrust-resisting joint system for valves and fittings
with Düker etec enamel

Novo plug-in sockets – the interesting alternative

The most important advantage of plug-in socket systems compared to flange systems is obvious for those with practical experience: economy of time. The assembly of a socket connection takes only about one third of the mounting time of a flange connection – including the thrust-resistant joint.

The Novo thrust-resisting joint goes one step further. Due to the intelligent separation of the sealing and thrust-resisting function in two separate socket chambers and rings, the same socket geometry can be used with ductile iron pipes, steel pipes*, PE-HD or PVC pipes.

The advantages at a glance:

- Short assembly duration compared to flange connections
- Fewer single components compared to flange connections
- Fewer fittings due to the elimination of EU pieces (flanged sockets)
- Thrust-resistant connections up to PN 25 or 40
- No need for concrete abutments, use in narrow ditches is possible
- Deflection up to 3°
- Electrical separation is possible
- NOVO-SIT® is suitable for trenchless laying
- Tension-free laying, as sockets do not transfer bending moments
- Pipe cuttings can be used immediately and without problems
- The Novo socket can be used universally for various pipe materials, therefore reduction of stock costs
- All Novo fittings and valves are available with high-quality enamelling inside and outside
- Dismantling is possible
- Range of diameters DN 80 up to 300, larger diameters on request

* steel pipes of the same diameter as the corresponding ductile iron pipes

Comparison of assembly duration between flanged and socket connections

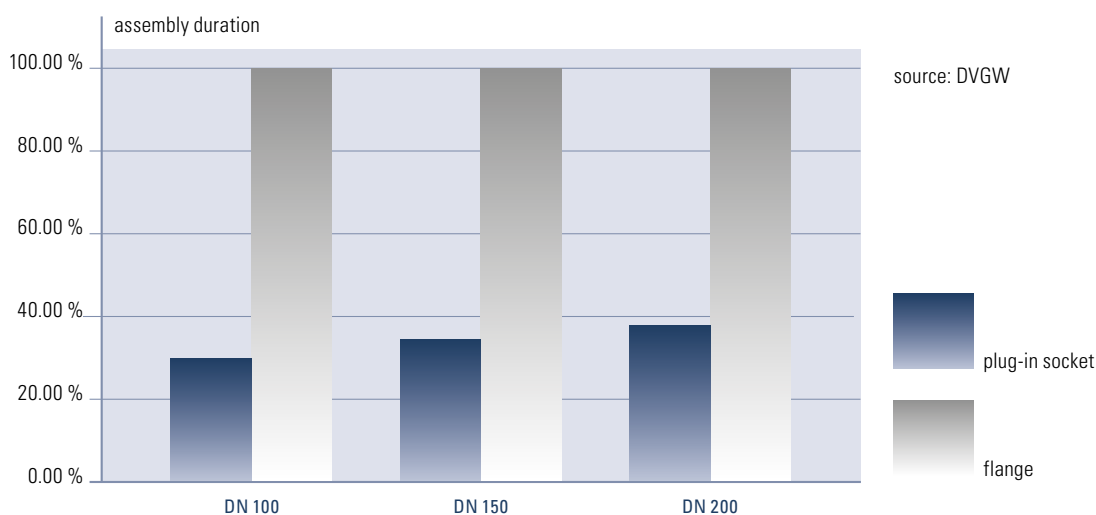

tive



Installed quick and easy - socket joint with only 19 assembling components.

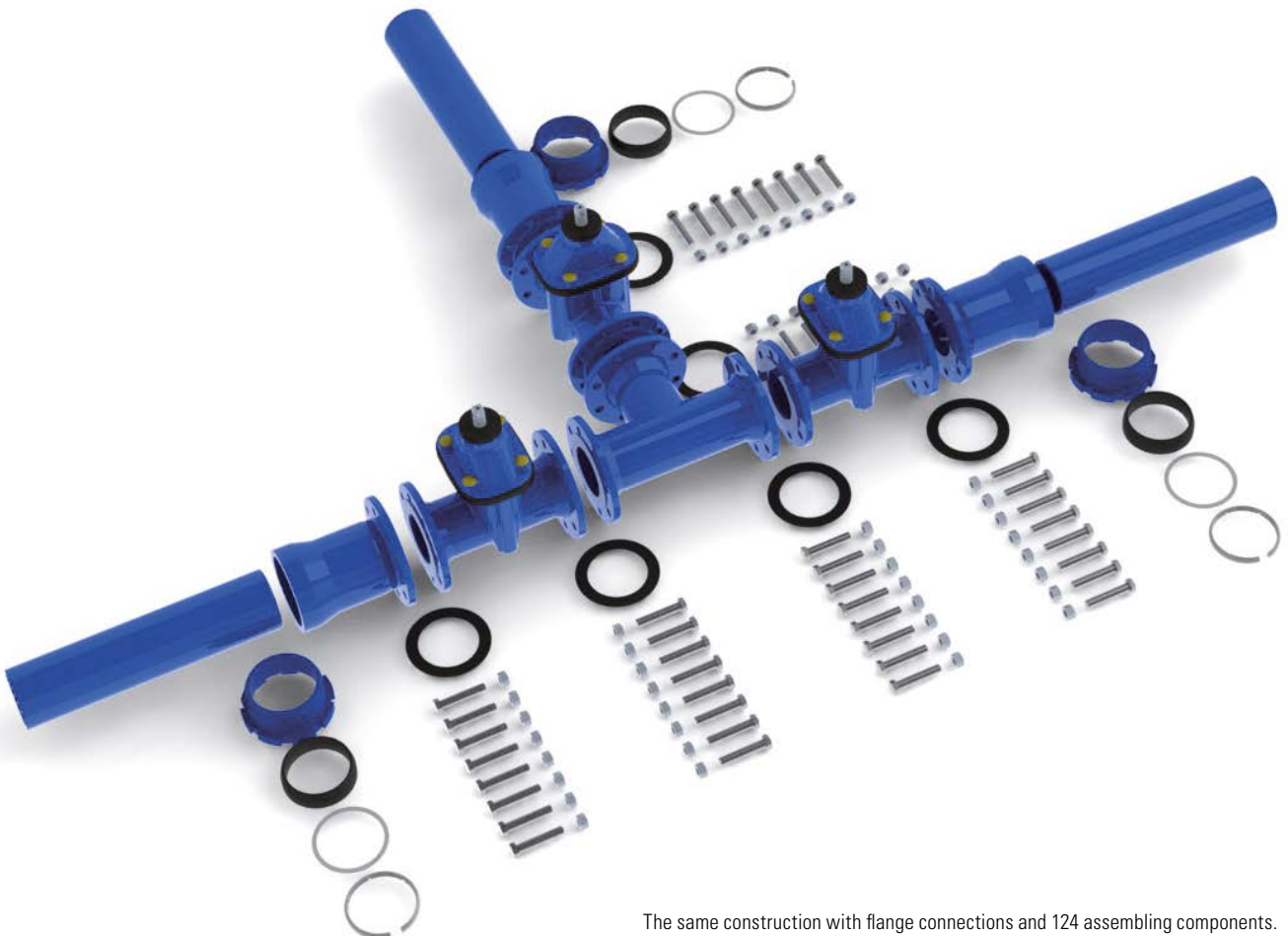

The same construction with flange connections and 124 assembling components.

Thrust-resistant joints as a system

NOVO-SIT® for ductile iron pipes

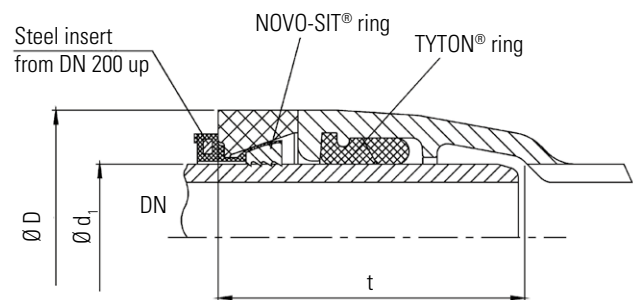

Dimensions NOVO-SIT®

DN mm	d ₁ mm	D mm	t mm	number of locking segments	allowable operating pressure PFA	pressure class	allowable operating pressure PFA	pressure class	deflection max.
80	98	141	119	5	40	C 100	25	C 50	3°
100	118	161	123	6	25	C 100	16	C 50	3°
125	140	188	126	7	25	C 100	16	C 50	3°
150	170	215	129	12	25	C 100	16	C 50	3°
200	222	271	138	13	25	C 64	16	C 50	3°
250	274	324	143	26	25	C 64	16	C 50	3°
300	326	381	152	30	25	C 50	16	C 50	3°

NOVO-Grip® III for PE pipes

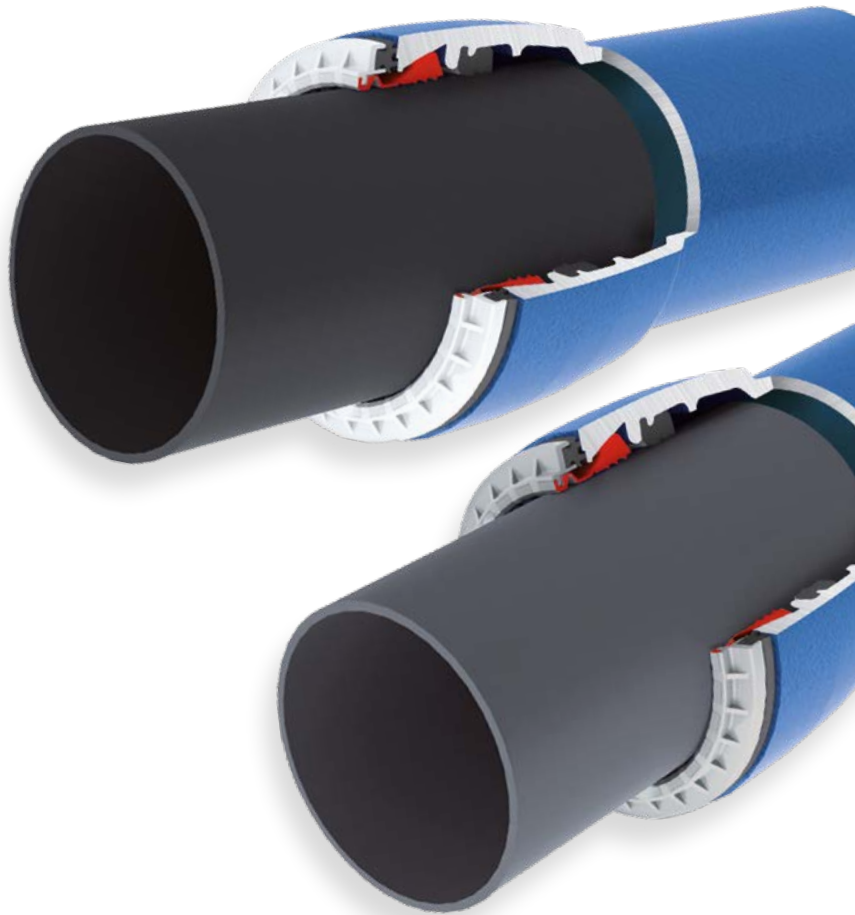
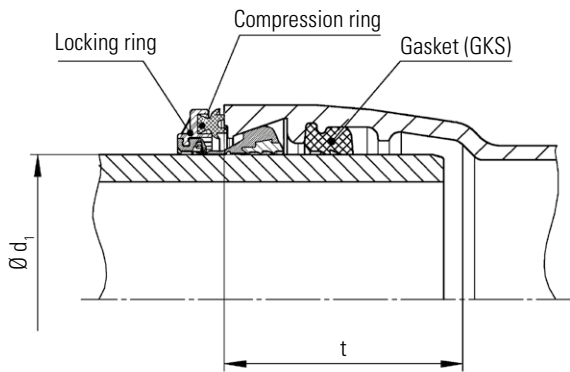

NOVO-Grip® for PVC pipes

Dimensions NOVO-Grip® III for PE pipes

NOVO-Grip® for PVC pipes

Ductile iron pipe or fitting DN	$\varnothing d_1$ plastic pipe DN/OD in mm	t in mm	PFA for SDR 11 bar	PFA for SDR 17 bar	PFA for PVC bar
80	90	119	16	10	16
100	110	123	16	10	16
125	140	126	16	10	16
150	160	129	16	10	16
200*	225	138	16	10	16

* Note: in DN 200 (d 225) for PE-HD and PVC pipes, it is not possible to use the standard Novo socket. The socket must be manufactured with an adapted geometry. Delivery is with pre-mounted connections. Marking „for PE-HD pipe“ or „for PVC pipes“

Easy and fast assembly

Assembly NOVO-SIT®:



1. Clean socket and spigot.



2. Insert TYTON® gasket as per the assembly instructions.



3. Insert NOVO-SIT® ring into the pre-chamber.



4. Measure the socket depth and mark the measure on the spigot.



5. Apply a thin layer of lubricant on the TYTON® gasket and the spigot, in particular at the chamfer.



6. Insert the spigot through the NOVO-SIT® ring into the socket until it rests concentrically against the sealing gasket. Use a customary laying device. Avoid deflection during assembly.

Attention:

any changes in circumferential direction (e.g. alignment of a lateral connection) must be carried out before the locking.



7. After assembly check the position of the TYTON® gasket with the help of a gauge between the locking segments on the complete circumference.

Note:

After assembly of the thrust-resistant connection, deflection of up to 3° is admissible.

On a 6m pipe, 1° deflection corresponds to approx. 10 cm of deviation from the neutral axis.

Use of the laying device



1. Lay the bracket with the drawbar handles around the Novo socket and tighten the clamping screw by hand.



2. Lay the bracket with the crank pins around the spigot and tighten the clamping screw by hand.



3. Connect the drawbars into the crank pins and bring the levers into the position shown here.



4. Now draw the spigot slowly into the socket by moving the levers. Avoid deflection. The locking of the Novo joint is made by an opposite movement of the levers, drawing the spigot slightly out of the socket.

Assembly of NOVO-Grip® III and NOVO-Grip



1. Clean socket and spigot.



2. Insert GKS gasket.



3. Insert NOVO-Grip® III ring into the pre-chamber.



4. Chamfer the pipe spigot.

5. For PE pipe: push in the whole length of the stabilising bush.



6. Drive the bracing wedge into the stabilising bush until it is tense. Cut off the protruding end of the bracing wedge.



7. Apply lubricant to the GKS gasket.



8. Insert the pipe through the NOVO-Grip® III ring into the socket until it rests concentrically against the sealing gasket. Avoid deflection during assembly.

Attention:

any changes in circumferential direction (e.g. alignment of a lateral connection) must be carried out before the locking.

® PVC

Dismantling of NOVO-SIT®, NOVO-Grip® III and NOVO-Grip® PVC:

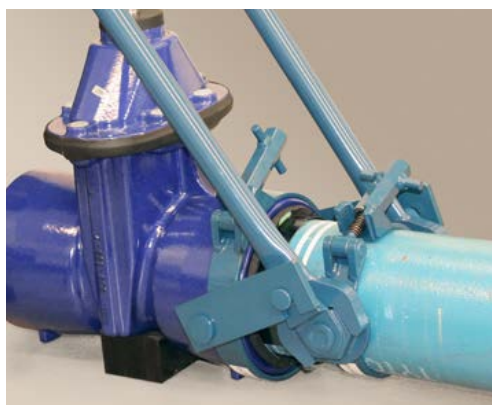

1. Push the spigot in up to the socket base.

2. Apply lubricant to the unlocking plates and drive them in all around with the help of the striking aid. (for NOVO-SIT®: at the locking segments marked on the outside of the ring)

3. Dismantle the connection with the laying device.

Accessories

Laying device V 300 D

consisting of:

- 2 levers, 1050 mm length
- 1 bracket with crank pin (to be mounted onto the spigot)
- 1 bracket with drawbar handles (to be mounted onto the socket)
- Available diameters: DN 80 up to 400; ductile iron or PE pipe (to be stated with the order)



stabilising bush for PE pipe



Dismantling accessories



striking aids



unlocking plates

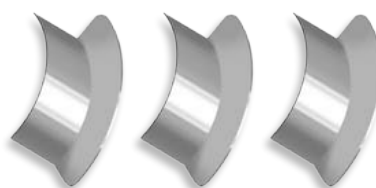

unlocking plates for plug-in hydrant

Düker etec enamel – your asset

The Düker etec inside and outside enamelling is the modern and sustainable protection of

Protection against inside corrosion

Enamel is diffusion-tight and therefore protects the ductile cast iron. Even in case of a local damage, a penetration of rust under the enamel is not possible thanks to the compound layer between enamel and cast iron.

Protection against incrustation

Enamel is extremely smooth. In the potable water pipeline, this means that the adhesion of sand and other dirt, in particular in the sealing seat of the valves, is effectively avoided thanks to this smooth surface.

Protection against biofilm and hygienical risks

Enamel is an anorganic material and as such is just as ideal for the transport of water as glass. Bacteria and germs do not find any nutritional base and cannot build up any noteworthy biofilm. Furthermore, water cannot dissolve any content out of the enamel.

Resistant to ageing

Enamel does not age. Unlike plastics, with enamel there is no embrittlement by the loss of softening agents or similar.



Düker[®]
etec



your investment

Protection against outside corrosion

Resistance to soil class III (very aggressive soils) as per DVGW worksheet GW9.

Protection against mechanical stress

Düker etec enamel is shock-resistant and extremely hard, so it is very well protected against friction, scratching or pressure.

Durable and sustainable

All these assets can be summed up in one sentence: enamelled fittings and valves are extremely durable due to their numerous advantages.

Enamelled components in water distribution networks are a sustainable investment into the future.



NOVO range of products

Gate valves

inside and outside enamel, for water

DN	80	100	125	150	200	250	300
Type 4004 Novo/Novo	•	•	•	•	•	•	•
Type 4004 Novo/spigot end	•	•	•	•	•	•	•
Type 2004 Novo/flange	•	•	•	•	•		

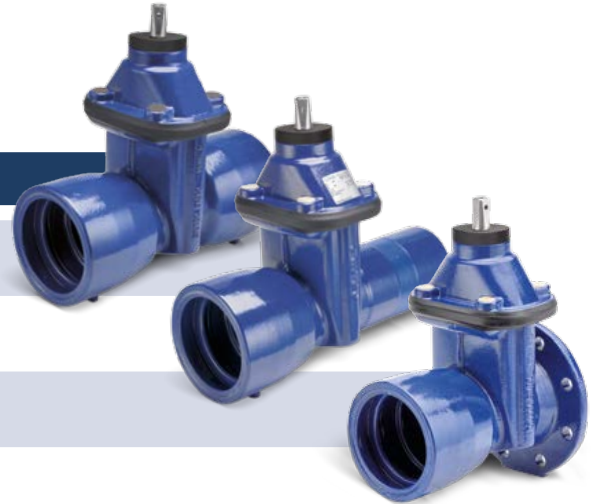

Further valves

inside and outside enamel, for water

DN	80	100	125	150	200	250	300	400	500
Butterfly valve type 4510 Novo/Novo				•	•	•	•	•	•
Underground hydrant type 304 S plug-in hydrant	•								



Accessories

DN	80	100	125	150	200	250	300
NOVO-SIT® thrust-resistant joint	•	•	•	•	•	•	•
NOVO-Grip® III thrust-resistant joint	•	•	•	•	•		
NOVO-Grip® PVC thrust-resistant joint	•	•	•	•	•		
Laying tool V 300 D	•	•	•	•	•	•	•

Novo fittings
inside and outside enamel

DN	80	100	125	150	200	250	300
MK 11°	•	•	•	•	•	•	•
MK 22°	•	•	•	•	•	•	•
MK 30°	•	•	•	•	•	•	•
MK 45°	•	•	•	•	•	•	•
MQ	•	•	•	•	•	•	•
MMK 11°	•	•	•	•	•	•	•
MMK 22°	•	•	•	•	•	•	•
MMK 30°	•	•	•	•	•	•	•
MMK 45°	•	•	•	•	•	•	•
MMQ	•	•	•	•	•	•	•

DN	80	100	125	150	200	250	300
EU	•	•	•	•	•	•	•
U Novo/Novo	•	•	•	•			
U Novo/screw-gland socket	•			•			
M	•	•	•	•	•		
MMN	•						
EN	•	•					
S		•	•	•	•	•	
PE adapter		•	•	•	•	•	
Socket ball fitting**	•	•	•	•	•	•	•
P	•	•	•	•	•	•	•



DN ₁ DN ₂	80	100	125	150	200	250	300
	80	80 100	80 100 125	80 100 125 150	80 100 125 150 200	80 100 125 150 200 250	80 100 150 200 250 300
MMA	•	•	•	•	•	•	•
MMB	•	•	•	•	•	•	•
B	•			•	•		
MI	•	•	•	•	•	•	•
IT		•	•	•	•	•	
R*		•		•	•		
MMR		•	•	•	•	•	•
MMNR		•	•				
MMB ball fitting**	•	•	•		•		
MMBB ball fitting**	•	•	•		•		

Further diameters on request!

* DN₁ spigot end, DN₂ socket

**available with or without hydrant connection flange DN 80 (8 holes, 4 holes) or with Novo socket DN 80 for plug-in hydrant

Socket systems in practice

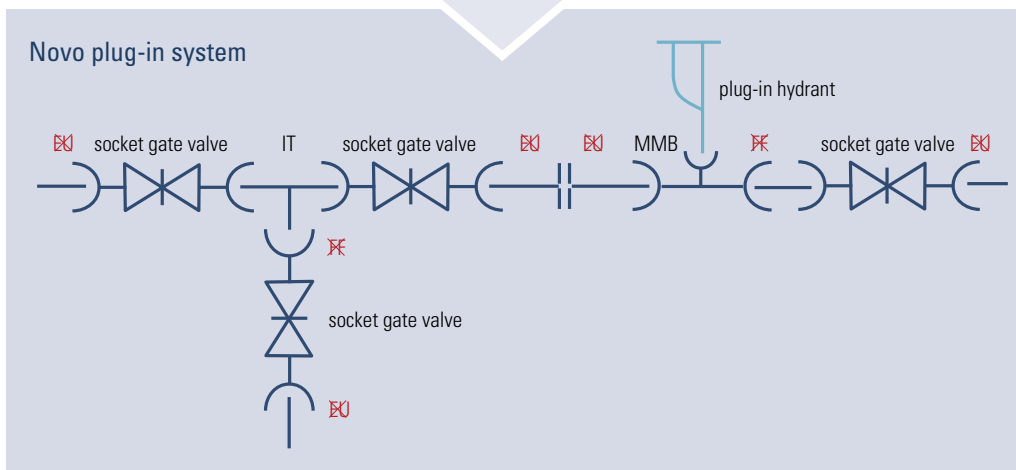
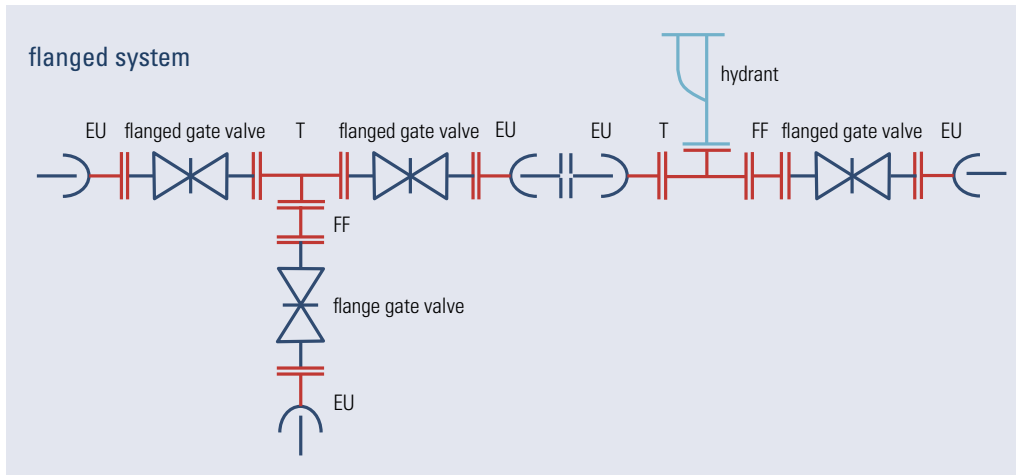

Compared to conventional flanged systems, the Novo system allows to eliminate numerous fittings and connections.

The economy of material and assembly costs is up to 30%!

flanged system

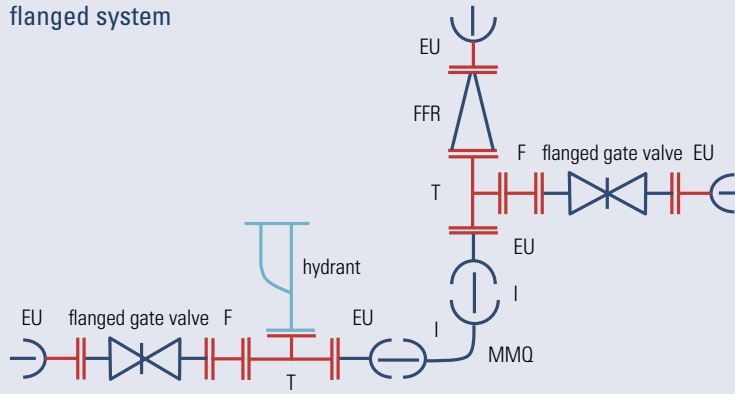

Novo plug-in system

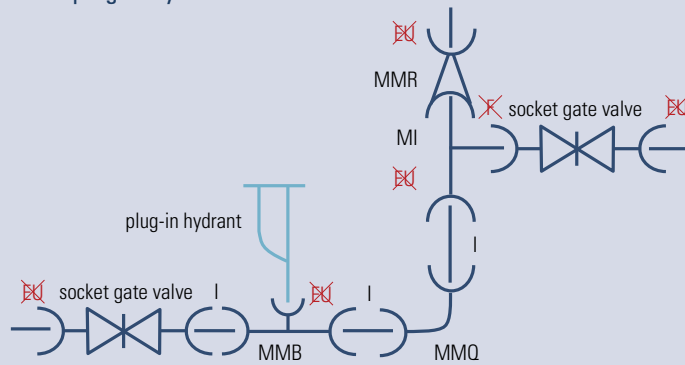

flanged system

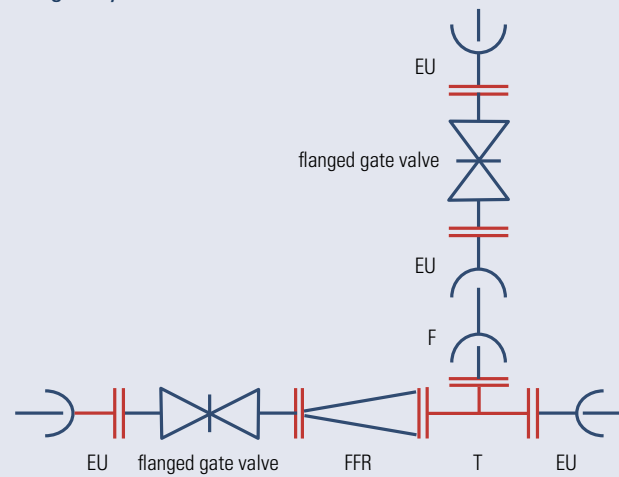

Novo plug-in system

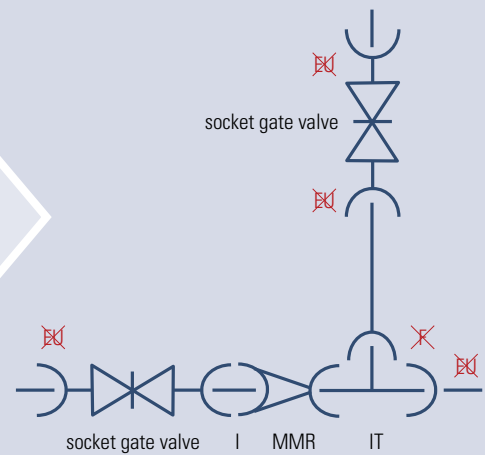

Assembly-friendly standard combinations

Examples for fittings and valves combinations

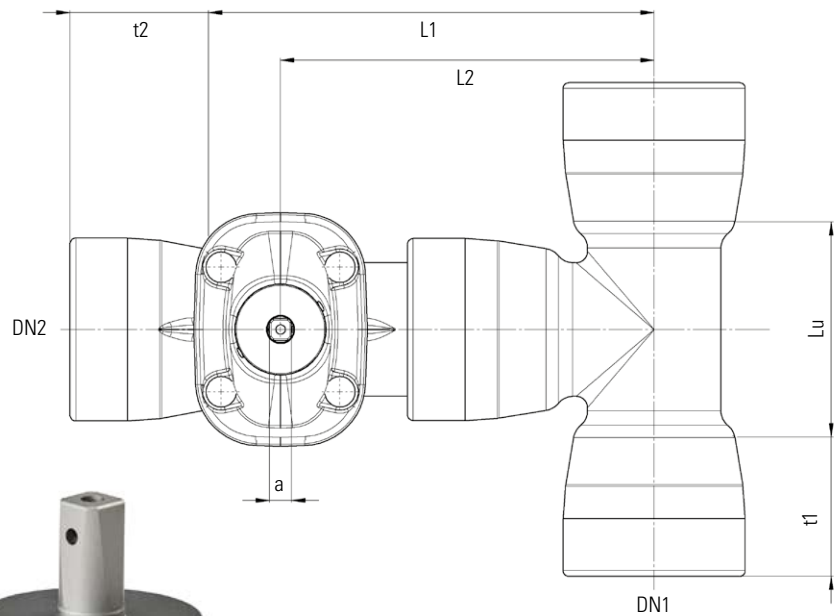

Multi I type 616
consisting of MMB Novo/Novo
and gate valve type 4004 Novo/spigot

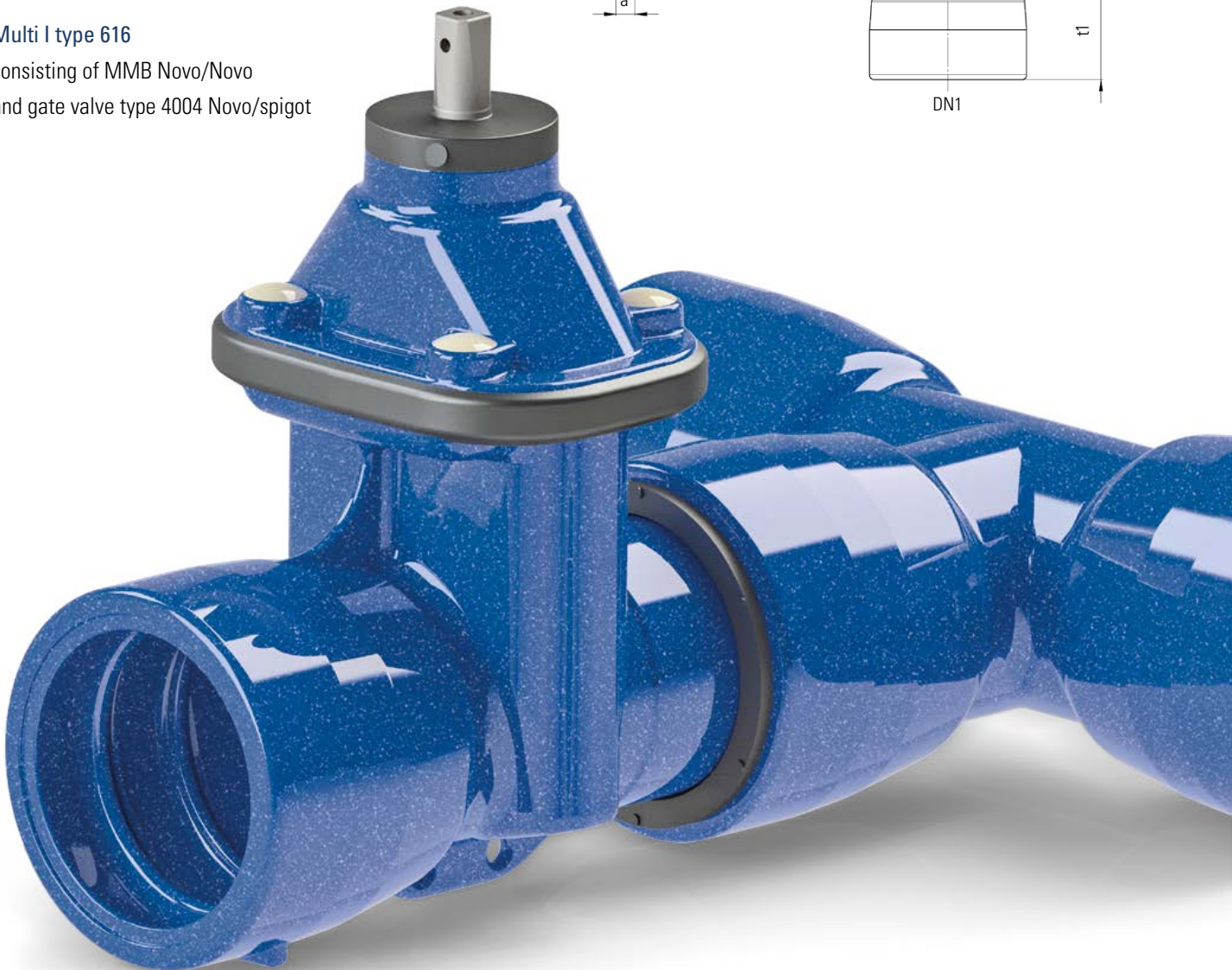

Dimensions of the combination Multi I type 616

DN1	DN2	PN	L1	L2	t1	t2	Lu	a
80	80	16	377	320	119	119	170	17
100	80	16	387	330	123	119	190	17
100	100	16	394	330	123	123	190	19
125	80	16	397	340	126	119	195	17
125	100	16	409	345	126	123	195	19
125	125	16	470	400	126	126	225	19
150	80	16	412	355	129	119	195	17
150	100	16	419	355	129	123	195	19
150	125	16	485	415	129	126	255	19
150	150	16	485	415	129	129	255	19
200	80	16	437	380	138	119	200	17
200	100	16	444	380	138	123	200	19
200	125	16	505	435	138	126	255	19
200	150	16	510	440	138	129	255	19
200	200	16	541	465	138	138	315	24
250	100	16	474	410	143	123	200	19
250	125	16	535	465	143	126	200	19
250	150	16	540	470	143	129	260	19
250	200	16	571	495	143	138	315	24
250	250	16	583	500	143	143	375	27
300	100	16	499	435	152	123	205	19
300	125	16	560	490	152	126	205	19
300	150	16	560	490	152	129	320	19
300	200	16	591	515	152	138	320	24
300	250	16	603	520	152	143	430	27
300	300	16	614	525	152	152	430	27



Special fittings with practical value

Examples for fittings and valves combinations

Multi III type 636

consisting of spigot T „IT” and
three gate valves type 4004 Novo/Novo

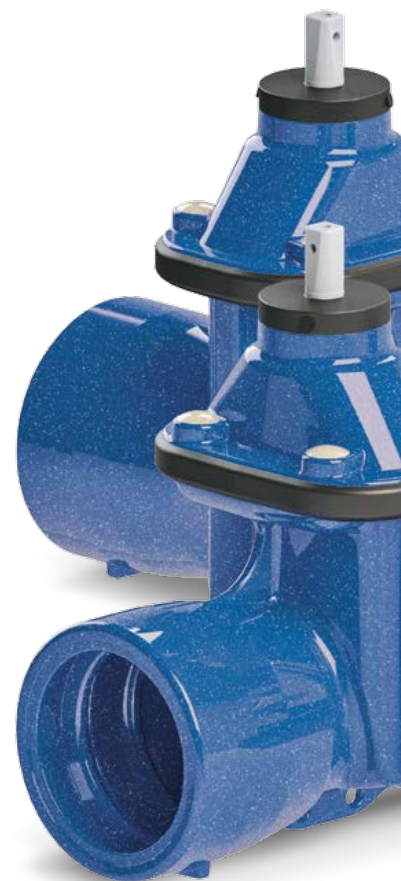
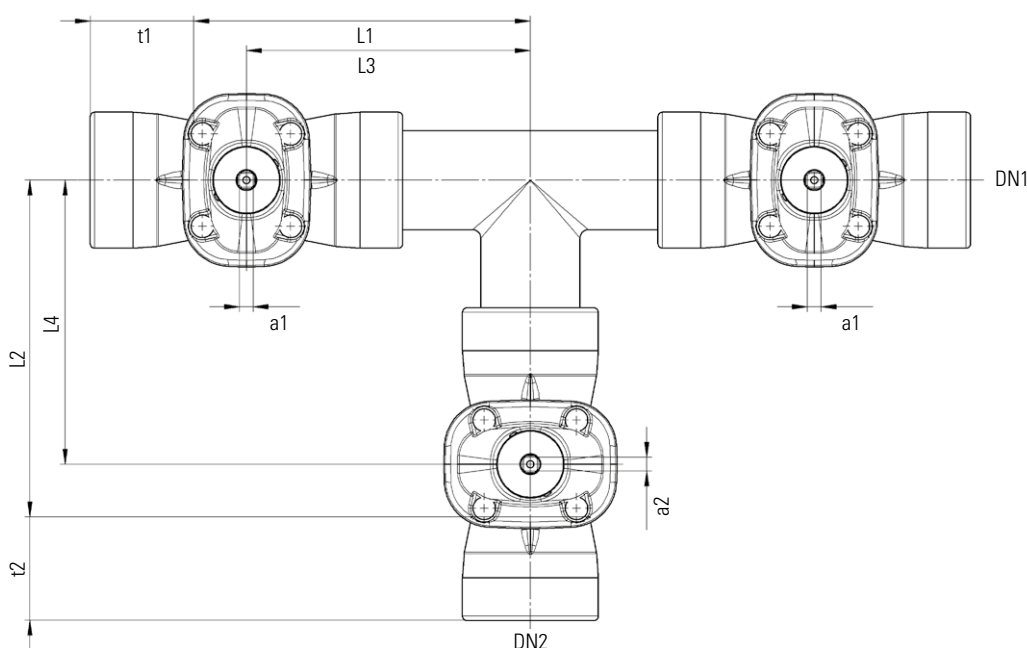

Dimensions of the combination Multi III type 636

DN1	DN2	PN	L1	L2	L3	L4	t1	t2	a1	a2	kg
80	80	16	384	384	327	327	119	119	17	17	51
100	100	16	402	402	339	339	123	123	19	19	63
125	100	16	440	427	370	364	126	123	19	19	75
125	125	16	440	440	370	370	126	126	19	19	84
150	100	16	450	437	380	374	129	123	19	19	86
150	125	16	450	450	380	380	129	126	19	19	93
150	150	16	450	450	380	380	129	129	19	19	102
200	100	16	477	452	401	389	138	123	24	19	116
200	125	16	477	465	401	395	138	126	24	19	123
200	150	16	477	465	401	395	138	129	24	19	131
200	200	16	477	477	401	401	138	138	24	24	153

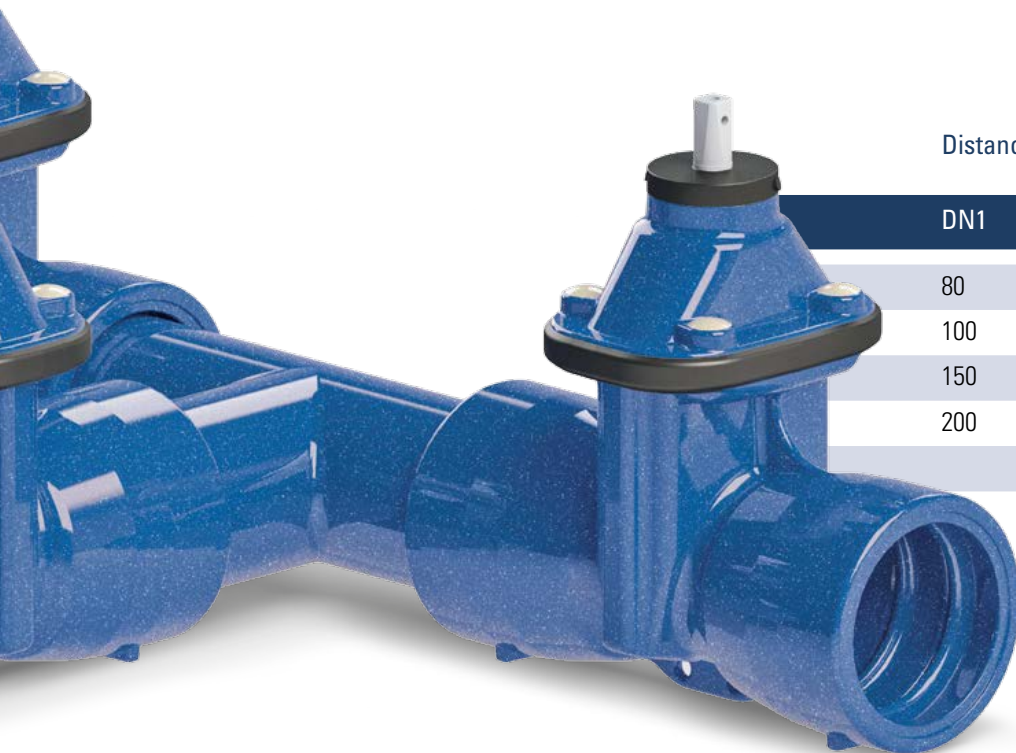

Distance between surface boxes

DN1	DN2	PN	L2	L3	L4
80	80	16	304	327	327
100	100	16	327	339	339
150	150	16	410	380	380
200	200	16	452	401	401

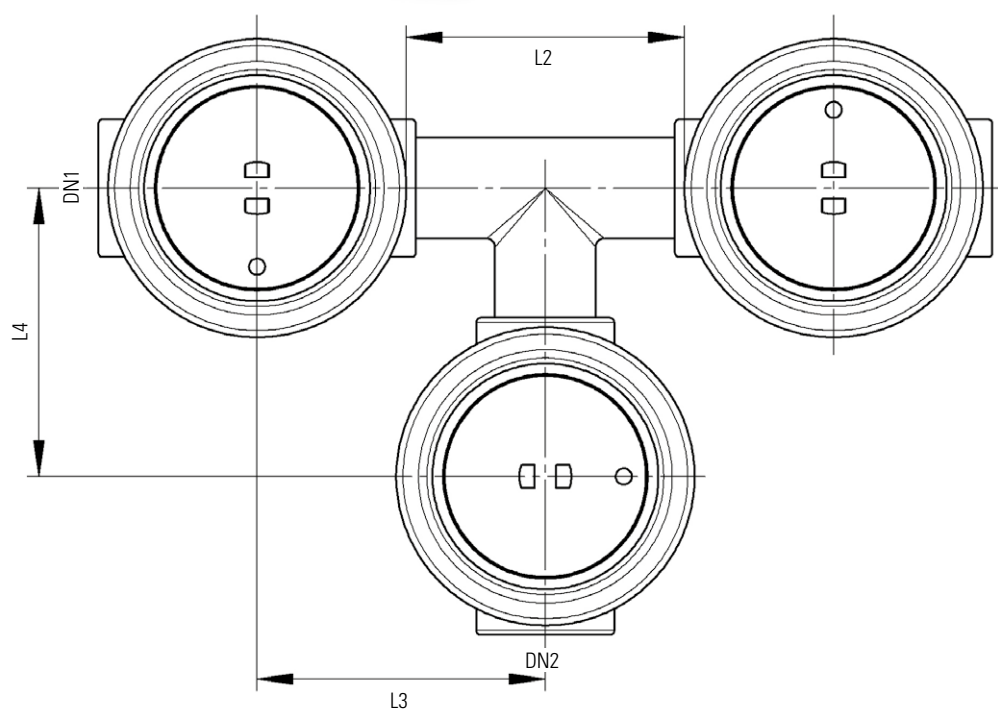

FITTINGS AND VALVES

DRAINAGE TECHNOLOGY

GLASS LINING TECHNOLOGIES

JOBGING FOUNDRY

Düker GmbH & Co. KGaA

Hauptstraße 39-41

D-63846 Laufach

Germany

Phone +49 6093 87-560

Fax +49 6093 87-246

E-Mail: sales.fittings-valves@dueker.de

Internet: www.dueker.de