

## Operating Instructions

# Resilient Seated Butterfly Valves

Type 451 double flanged  
for water/ gas (PN 10/ 16/ 25)

Item no. of the operating instructions: 764846 Issue 04, 2018, 19 pages  
Specifications subject to change without notice

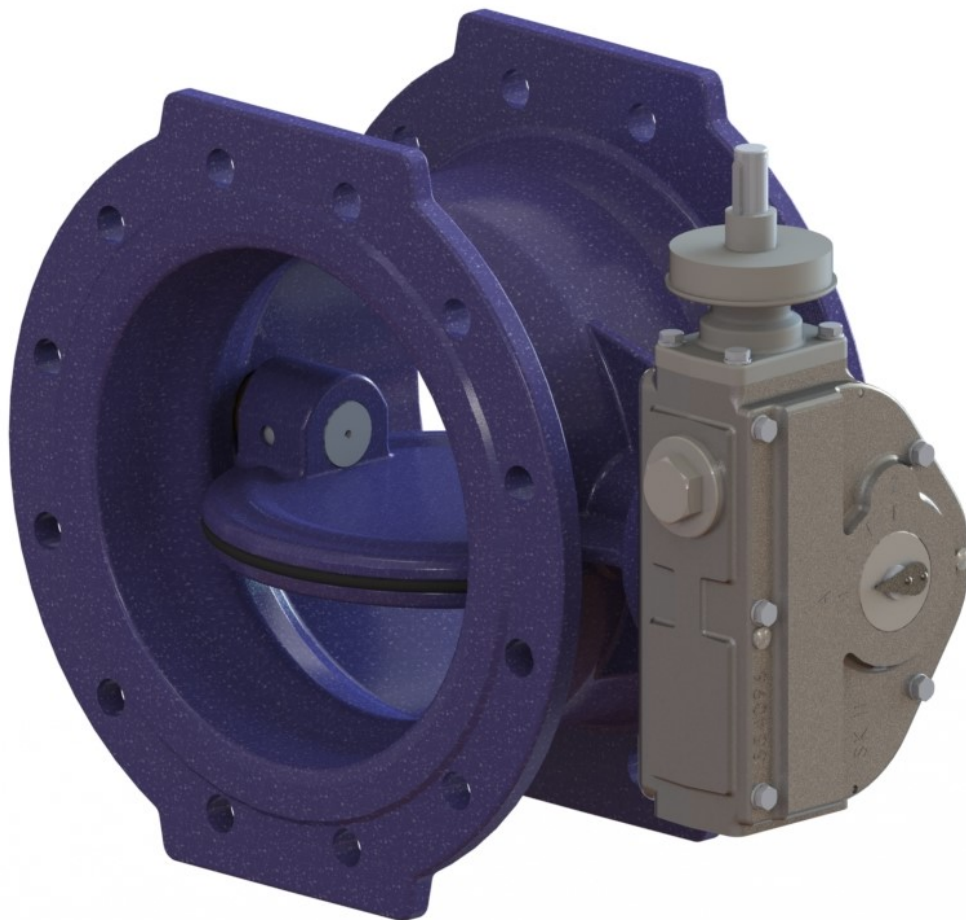

1	Intended use	3
2	Safety precautions	3
2.1	General safety instructions	3
2.2	Safety instructions for the owner/operator	3
2.3	Special risks	4
3	Transport and storage	5
4	Pressure test on the pipeline	6
5	Installation into the pipeline	6
5.1	General information	6
5.2	Operational steps	7
6	Functional description	7
7	Drawing and parts list	8
7.1	Drawing	8
7.2	Part list	9
8	Operation	10
9	Troubleshooting	12
10	Service and maintenance	13
10.1	Maintenance	13
10.2	Replacing the profile sealing	13
10.3	Adjusting the retaining ring	16
10.4	Tightening torque gear flange	17
10.5	Tightening torque blind pin	18
10.6	Tightening torque retaining ring	18

## 1 Intended use

After the installation into a pipeline, butterfly valves are only intended for stopping or allowing media to pass within the range of the permitted operating conditions (temperature and pressure limit "PN" labeling on the valve, unless stated otherwise).

These valves are preferably intended for liquid media, such as drinking water or gas. Any deviating operating conditions or areas of application are subject to manufacturer approval.

We will not assume any responsibility for consequential damage caused by



- unauthorized modification of the valve and the accessories supplied
- improper operating or operating conditions
- acts of god

To control in continuous operation shut-off valves are not usable.  
Cavitation is definitely to be avoided.

## 2 Safety precautions

### 2.1 General safety instructions

The safety regulations applicable to valves are the same as those for the pipeline in which they are installed. These instructions only specify those safety instructions which have to be additionally noted and observed for valves.

### 2.2 Safety instructions for the owner/operator

The owner/operator of the valve is responsible to ensure that the valve is only used as intended. It is not in the responsibility of the manufacturer. Only competent persons, with suitable qualifications for pressure pipes, operate and service the valve.



Do not operate a valve whose permissible component operating pressure ("Ps") and maximum permissible operating temperature ("Ts") are not sufficient for the operating condition. The area of application is marked on the valve.



Within the permissible operating temperatures, there is a risk of injury when working on the piping components at temperatures below 10 ° C and above 40 ° C. Therefore, protective measures should be taken in these cases.



Operating fluids must comply with the specification of the valve. The manufacturer assumes no liability for corrosion damage caused by aggressive media. Failure to comply with this requirement can endanger life and limb and cause damage to the piping system.

- The valve must be properly installed in the pipeline.
- In the pipeline the usual flow velocities (e.g. according to EN 1074-1: 2.5 – 5 m/s for liquids must not be exceeded in continuous service.
- Abnormal operating conditions such as vibrations, water hammers, erosion, cavitation and greater fractions of solids in the medium – especially wearing solids – must be clarified with the manufacturer.

## 2.3 Special risks



Before opening and/ or repairing valve, the pipe must be completely depressurized. The pipe should be completely emptied before replacing wearing part



For valves used as an end fitting: In normal service a blank flange or a cover must be mounted on the free pipe connection or the valve must be securely locked in the "SHUT/CLOSED" position. Caution on closing such a valve: Beware of risk of crushing!

### 3 Transport and storage



All valves must be carefully transported and stored.



The valves are fully enameled or powder-coated. The coatings are shock-sensitive and must be protected against impact stress.



The gaskets are sensitive to light: Unpackaged valves may only be exposed to bright daylight or ultraviolet light for a very short time. This is why the openings are sealed with protective caps. Valves must be stored in darkened rooms, in their original packaging with the protective caps.



In the event of storage over an extended period of time, the storage location should be frost-protected, cool, dry, dark and free of dust. Alternatively, the valves may also be packed in order to fulfill these conditions.

The valve should be stored on a pallet or similar support and only transported with suitable tools such as wide straps to its designated point of installation. Do not use chains!

## 4 Pressure test on the pipeline

- New installed pipelines should be carefully flushed first to wash out all foreign bodies.
- Valve open: The test pressure may not exceed the value  $1.5 \times \text{PN}$  (see valve markings).
- Valve closed: The test pressure may not exceed the value  $1.1 \times \text{PN}$  (see valve markings).

## 5 Installation into the pipeline

### 5.1 General information



Only original spare parts from the manufacturer may be installed.



The sealing surfaces of the flanges are designed for mating flanges with smooth sealing strips, according to EN 1092 or Stock Finish according to ANSI B 16.5. Other flange shapes must be agreed with the manufacturer. Elastomer gaskets according to the DVGW Guidelines W 270 are recommended, preference is to be given to flange seals with a metal core according to EN 1514 Part 1.



The same instructions apply to the installation of Düker butterfly valves in a pipe as for the connection of pipe elements according to EN 1092 and BS standards. It is assumed that the corresponding instructions are known and are followed. They are not part of these operating instructions. The following installation instructions additionally apply to butterfly valves



In order to prevent electrochemical corrosion, the formation of potentials should be avoided when installed in pipes made of non-corrosive steel. Especially in humid environments, which lead to condensation on the valve, it is therefore advisable to electrically disconnect the flange connection elements.

## 5.2 Operational steps

- Transport the valve to the point of installation in its protective packaging.
- Remove all packaging materials from the valve.
- Check valve for transportation damage. Damaged valves must not be installed.
- Check coating for damages. The coating may be mended with a repair kit.
- Ensure that only valves whose nominal pressure and connection dimensions correspond to the use conditions are installed. See markings on the valve.
- Before installing, the valve and the pipe must be cleaned to remove dirt and hard bodies.
- Perform a functional test before installation: The valve must open and close correctly.
- The mating flange of the pipe must be concentric and plane-parallel.
- Butterfly valves can be installed irrespective of the direction of flow.
- The preferred installed position is in a horizontal pipe with vertical stem and hand wheel facing upwards.
- The valve should have an adequate ground support.
- The connection screws must be uniformly tightened crosswise.
- To ensure the function and compliance with the drinking water hygiene standards, only original Düker original spare parts may be installed.
- When pushing the valve and the seals into an installed pipe, the distance between the pipe ends must be that all connection faces and seals remain undamaged. The gap should not be larger than necessary, to ensure no additional stresses in the pipe during installation.
- The valve must be installed stress-free.

## 6 Functional description

The butterfly valve is a valve for controlling the flow of a fluid in a pipeline. The valve is installed in the pipe with flange connections. The Düker butterfly valves have a flow optimized, double-eccentrically mounted disc. The profile seal can easily be readjusted and easily replaced.

The disc is connected to the drive shaft and guided out of the housing. The bearing shafts run in maintenance-free bearings. Through internal and external O-rings, the shafts are sealed.

The butterfly valve can be operated either with hand wheel, Düker installation kit, electric actuator and hydraulic or pneumatic rotary actuators. The stop of the slider-crank mechanism is adjustable for the end position "CLOSED".

The use of extensions to increase the operating torque during hand wheel operation is not permitted as this will damage the valve. The valve is closed clockwise and opened in the opposite direction.

## 7 Drawing and parts list

### 7.1 Drawing

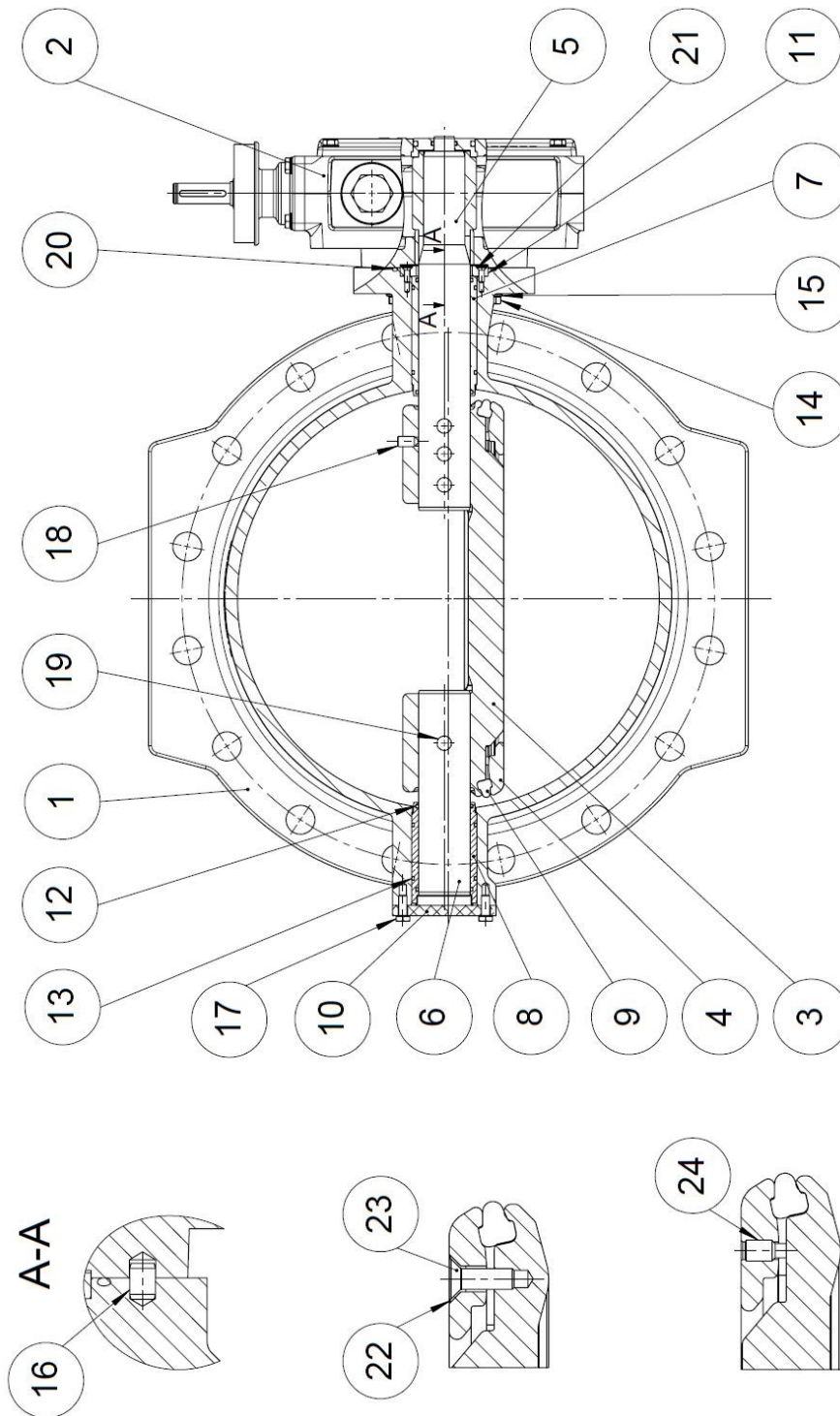



## 7.2 Part list

<b>item</b>	<b>description</b>	<b>item</b>	<b>description</b>
1	Body	13	O-ring
2	Gear box	14	Hexagon head screw
3	Disc	15	Washer
4	Retaining ring	16	Cylindrical notch pin
5	Shaft	17	Hexagon head screw
6	Bearing journal	18	Grub screw
7	Bearing sleeve A	19	Taper pin
8	Bearing sleeve B	20	O-ring
9	Profile sealing	21	Countersunk screw
10	Blind pin	22	Washer
11	Connection ring	23	Countersunk Screw
12	O-ring	24	Grub Screw

## 8 Operation



butterfly valve with hand wheel

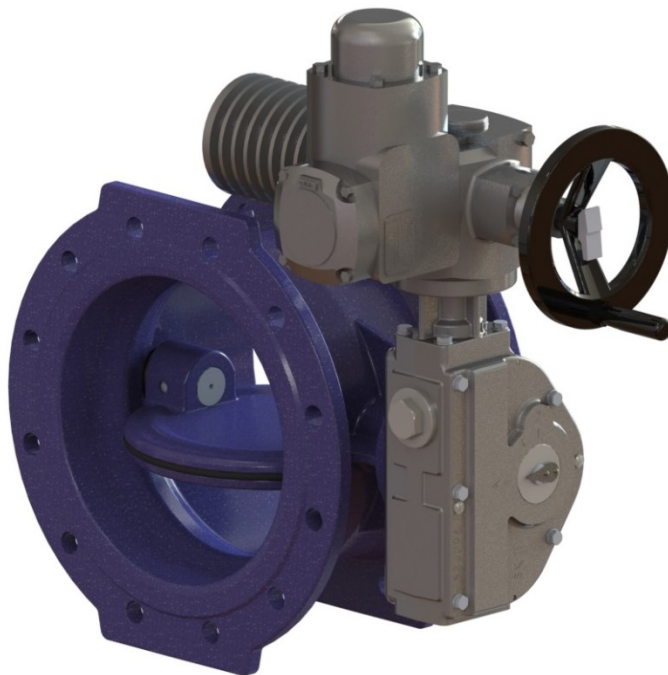

butterfly valve with electric actuator

## Allocation of electrical actuators

DN	PN	Düker Gear Type	AUMA Reduction Gear Type	Turns for OPEN - CLOSE	MT nom. Gear Input (Nm)	AUMA Actuator Type			
700	10	SK IV B / F30	-	43	110	SA 10.2			
	16		GP 14.1 (4:1)	172	70				
	25				100				
10	110								
750	16				GS 200.3 / F30		GZ 200.3 (16:1)	216	60
	25								
800	10				SK IV B / F30		GP 14.1 (4:1)	172	110
	16								
900	10		GS 250.3 / F35	GZ 250.3 (16:1)	212		110		
	16								
1000	10	SK IV B / F30				GP 14.1 (4:1)		172	110
	16								
1200	10	SK IV B / F30	GP 14.1 (4:1)	172	110				
	16								



To operate normal hand forces are sufficient. When using a rotary device, make sure that the maximum actuation torques do not exceed 200 Nm.

## 9 Troubleshooting

### Leakage at a connection to the pipeline:

- Tighten the flange screws.
- If leakage continues: Repair necessary.

### Leakage at disc:

- Check if valve is 100% closed. If so, check if the valve has been closed with the required torque.
- If leakage persists, open / close the valve several times under pressure.
- If the valve continues to leak, repair is necessary. Change the rubber seal.
- Request replacement parts and instructions from Düker.

### Further Hints:

- Spare parts are to be ordered with all information of the marking on the valve. Only DÜKER original parts may be installed.
- If it is determined after removal that the housing and / or internal parts are not sufficiently resistant to the medium, the manufacturer DÜKER should be contacted.

### Dysfunction:

- Remove and inspect the fitting. If the valve is damaged: Repair is necessary. Request replacement parts and required instructions from DÜKER.



The valve is sealed by O-rings. Before the blind pin or the connecting ring on the valve is loosened, the pressure in the pipeline must be completely reduced. When replacing wearing parts (e.g. profile seal or O-rings), the line should be completely emptied. When disassembling the capital 2 safety instructions must be strictly observed.



Please note that Düker GmbH assumes no liability for damage and malfunctions resulting from non-compliance with the operating instructions.

## 10 Service and maintenance

### 10.1 Maintenance

It is recommended to operate fittings that remain permanently in one position three to four times a year.

### 10.2 Replacing the profile sealing

- Mark the position of the retaining ring (4) to the disc (3) (yellow line).

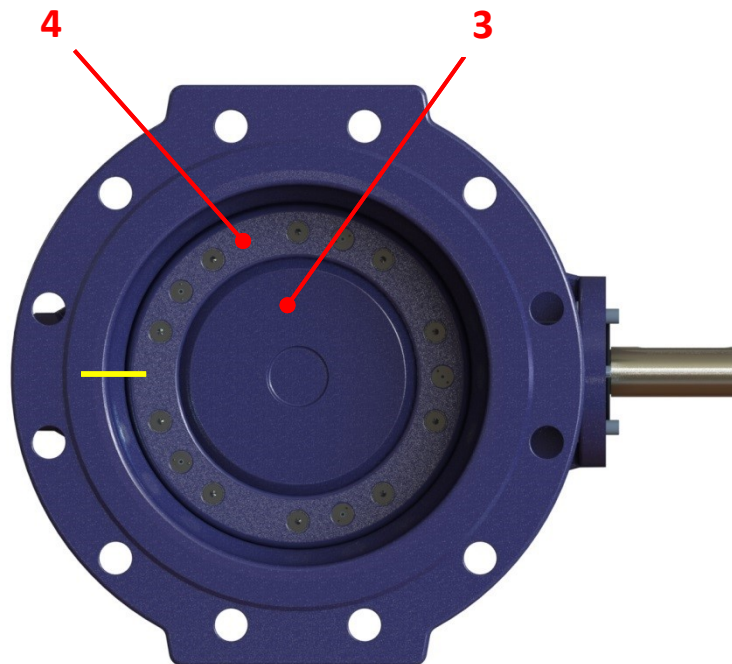

- Loosen the countersunk screws (23) of the retaining ring when the valve is closed. Leave grub screws (24) untouched, because they reproduce the tensioned position of the profile sealing.

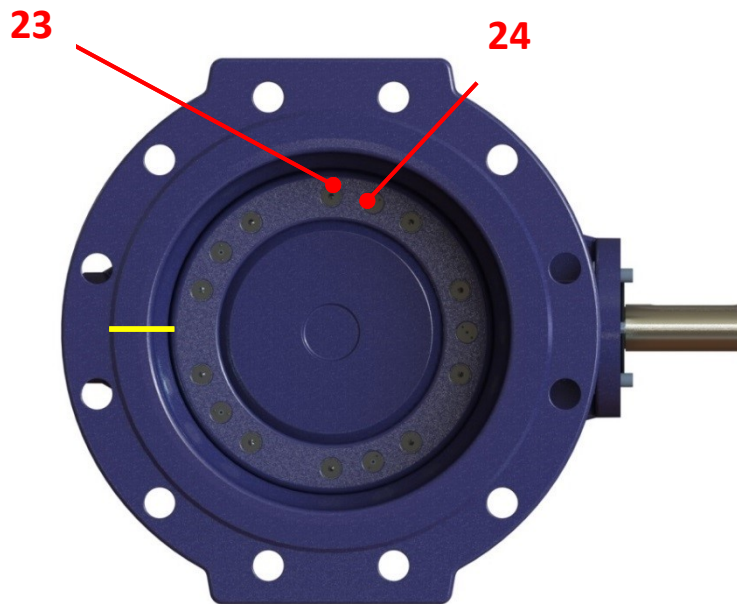

- Move the disc (3) to the open position and remove the countersunk screws (23).
- Remove the retaining ring (4) after removing the countersunk screws (23).
- Replace profile sealing (9), remove soiling in sealing area. Check the exact location of the profile sealing (9) in the retaining groove.
- Fill threaded holes for the countersunk screws (23) with glass adhesive.
- Tighten the countersunk screw (23) on the retaining ring (4) to the specified torque.

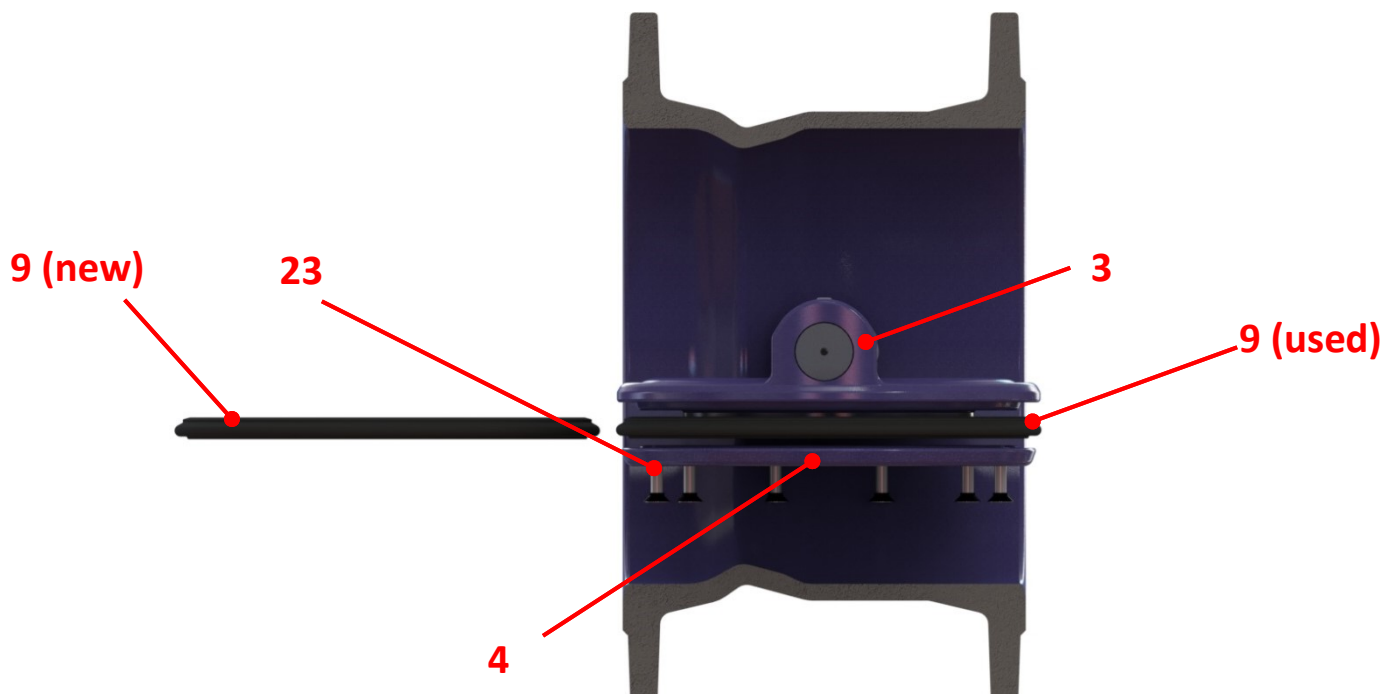

- Move the valve disc (3) to the "CLOSED" position.
- Pressure test; depending on the pressure level.

In case of leakage, adjust retaining ring in closed position. To do this loosen grub screws (24) and tighten countersunk screws (23) with permissible torque. After this operation, turn the grub screws (24) clockwise to make contact with the surface of the butterfly disc (3).

### 10.3 Adjusting the retaining ring

The retaining ring (4) can be adjusted in the CLOSED position of the butterfly valve. For this purpose, the grub screws (26) are released, while the countersunk screws (25) are tensioned with a permissible torque. After this procedure, the grub screws (26) are to be fixed by turning clockwise

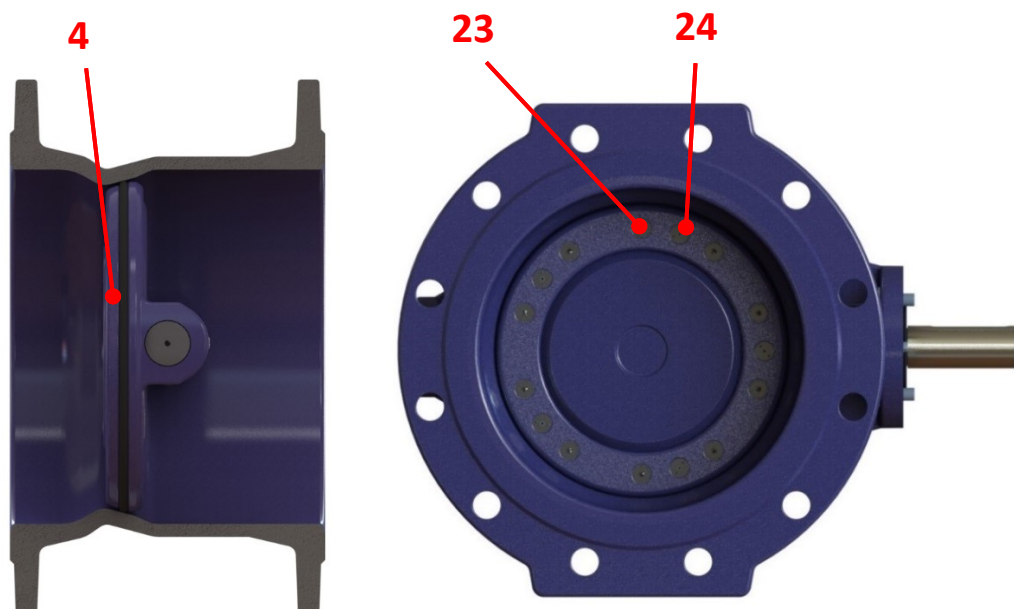

To ensure proper function and compliance with drinking water hygienic requirements, only original Düker spare parts may be installed.



## 10.4 Tightening torque gear flange

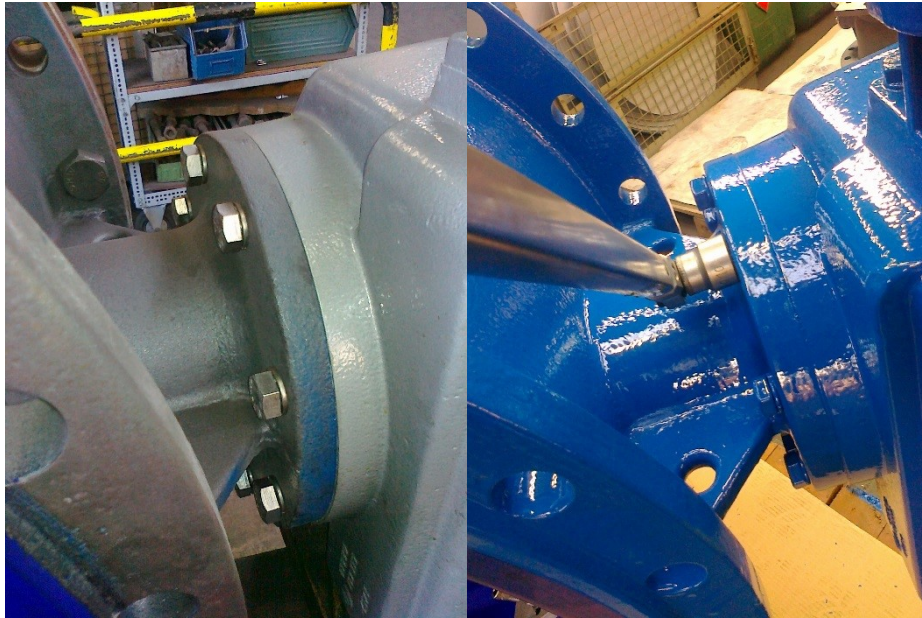

	<b>Gearbox attachment A2-70 und A4-70</b>				
<b>Dimension</b>	<b>M10</b>	<b>M12</b>	<b>M16</b>	<b>M20</b>	<b>M24</b>
<b>Permissible torque [Nm]</b>	35	150	180	290	500

### 10.5 Tightening torque blind pin

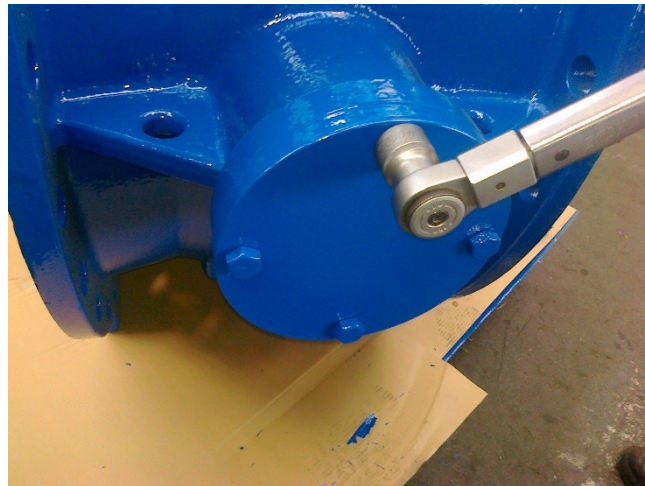

	<b>Screws for fixing the blind pin A2-70 und A4-70</b>				
<b>Dimension</b>	<b>M10</b>	<b>M12</b>	<b>M16</b>	<b>M20</b>	<b>M24</b>
<b>Permissible torque [Nm]</b>	35	150	180	290	500

### 10.6 Tightening torque retaining ring

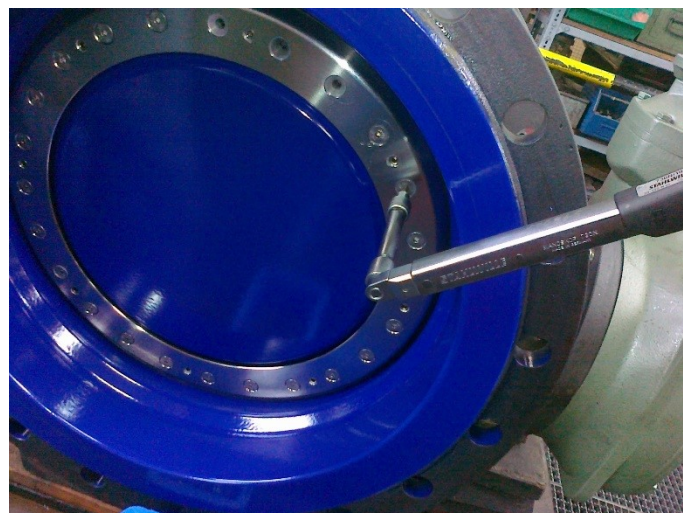

	<b>Screws for fixing the retaining ring</b>		
<b>Dimension</b>	<b>100 – 300</b>	<b>350 – 600</b>	<b>700 – 1200</b>
<b>Permissible torque [Nm]</b>	7 - 10	10 -12	12 - 15

The distribution and reproduction of these Operating Instructions, utilization and communication of their contents to others is authorized exclusively for the purpose of ensuring the correct installation and operation of the Düker product treated in the document. For all other purposes, distribution, reproduction and utilization of the contents, also in excerpts, is prohibited. Offenders will be held liable for the payment of damages. All rights reserved in the event of the grant of a patent, utility model or design.