

Operation instructions

Gate Valve

Type 3004 with blow-off pipes and
welding studs for steel pipes
for gas

Item no. of the operation instructions: 764835, issue 02, 9 pages, 2017
Specifications subject to change without notice



for hand wheel and stem extension set

- 1. Intended use**
- 2. Safety precautions**
 - 2.1 General safety instructions**
 - 2.2 User safety instructions**
 - 2.3 Special risks**
- 3. Transport and storage**
- 4. Installation into the pipeline**
 - 4.1 Venting function**
- 5. Operation**
- 6. Service and maintenance**
- 7. Drawing and parts list**
- 8. Diagnostics and trouble shooting**

1. Intended Use

After the installation into a pipe system, shut-off valves are only intended for stopping or allowing media to pass within the range of the permitted operating conditions (temperature and pressure limit "PN" labeling on the valve, unless stated otherwise).

Gate valves are used exclusively for open/closed operation in pipe systems.

We will not assume any responsibility for consequential damage caused by

- unauthorised modification of the valve and the accessories supplied
- improper operating or operating conditions
- acts of God

2. Safety Precautions

2.1 General safety instructions

The same safety regulations apply for valves as for the pipe system in which they are installed. The following instructions only include additional safety instructions to be observed for valves.

When using this valve, the generally recognized rules of good practice (standards, DVGW regulations, VDI guidelines or other regulations valid at the place of installation) must be observed.

The valve must be professionally installed into the pipeline.

2.2 User safety instructions

The operator of the valve must ensure that the valve is only used in accordance with the intended use. This is not the responsibility of the manufacturer. The valve may only be operated by properly qualified and trained staff. The operating manual and the corresponding safety instructions must be read and understood.



It is prohibited to use any valves with a nominal pressure ("PN") and maximum admissible operating temperature insufficient for the operating conditions. The approved range is indicated on the valve.



Warning: Temperatures below 10 °C and above 40° C during work on the pipeline parts involve the risk of injury. Protective measures must be taken accordingly.



Operating media must correspond to the specification of the valve. The manufacturer does not assume any liability for damage resulting from corrosion caused by aggressive media. Neglect of these regulations may result in imminent danger to life and health, and may cause damage to the pipeline.

2.3 Special risks



Be sure to free the pipeline from any pressure and risk prior to disassembly, maintenance and repair of the valve. During disassembly the medium may leak, therefore the pipeline and the valve must be completely emptied.

The energy supply must be switched off.

3. Transport and storage

All valves must be carefully transported and stored.



The valves are fully enamelled or powder-coated. The coatings are shock-sensitive and must be protected against impact stress.



The gaskets are sensitive to light: Unpackaged valves may only be exposed to bright daylight or ultraviolet light for a very short time. This is why the openings are sealed with protective caps. Valves must be stored in darkened rooms, in their original packaging with the protective caps.



In the event of storage over an extended period of time, the storage location should be frost-protected, cool, dry, dark and free of dust. Alternatively, the valve may also be packed in order to fulfill these conditions.

The valve should be stored on a pallet or similar support and only transported with suitable tools such as wide straps to its designated point of installation. Do not use chains!

4. Installation into the pipeline

The Gate valve with the specified DIN length may only be welded into the pipeline in the "metal arc hand welding process" (electrical welding). The welding studs comply with EN 12627.



All legal requirements, standards and specifications according to DVS e.g. ISO 3834-1 "Quality requirements for fusion welding" shall be observed.

For the installation of valves into pipe systems, the same instructions apply as for the connection of pipe system components. The following work steps must be observed:

- Transport the valve to the point of installation in its protective packaging.
- Remove all packaging materials from the valve.
- Check valve for transportation damage. Damaged valves must not be installed.
- Check coating for damages. The coating may be mended with a repair kit.
- It needs to be ensured that nominal pressure and connecting dimensions of the valve are in correspondence with the operating conditions. See marking on the valve.
- Remove dirt and hard foreign matter from valve and pipelines prior to installation.
- A functional test must be carried out prior to installation: The valve must shut and open properly.
- The connections of the pipeline must be adjusted concentric to the valve.

- The valve must be installed in a horizontal pipeline, with the stem in vertical position.
- The valve should have adequate floor support.
- Both welding studs must not be shortened.
- Make sure that the surfaces in the welding area are bare metal, free from zinc and dry.
- To prevent a strong heating of the sealing wedge, the valve must be fully open.
- In no case, the stem may be used as the opposite pole, but only the pipe to be welded.
- The valve must be welded in free of tension
- The valve should only be closed when the housing is no more than lukewarm.
- Check the weld seam during the pressure test of the pipeline.
- Adjust the length of the blow-off pipes to the covering height.
- Then insert the blow-off pipes into the free pipe ends of the valve and weld them on. Observe the welding instructions.
- When using detergents and disinfectants it must be ensured that these products do not attack the materials and gaskets of the valve.
- During the pressure test of the pipe system with the installed valve, the following test pressures may not be surpassed:



Valve opened: The test pressure must not exceed 1.5 x PN (see type plate).
Valve shut: The test pressure must not exceed 1.1 x PN (see type plate).

- The valve must be protected from dirt which can derive from work (e.g. painting, masonry and concrete work) in the area of the valve.

4.1 Venting function

To vent the system, unscrew the plug on the ball valve.

When the gas line is filled, the ball valves are opened and the air in the pipeline can escape. When this air has been removed, the ball valve is closed, the plugs screwed back on and the system is ready for operation.

When repairing the gas line, the corresponding part of the pipeline system is shut off.

The gas is vented through the venting tubes. The system is then purged with nitrogen.

This ensures that the remaining gas residues are thoroughly removed. Safe working is possible on the gas line. The venting is as described above.

5. Operation

The valve is shut by turning it clockwise and is opened by turning it in the opposite direction. Manual power suffices to operate the valves. Use of extensions to increase actuating torque is not permissible, since this will cause damage to the valve.

Operating torques

The stated operating torques are the max. permissible torques for full differential pressure at the actuating stem, these are described in EN 1074-2.

nominal diameter DN	max. operating torque as per EN 1074-2 MOT Nm	no. of turns for closing	stem square mm
80	80	16	17
100	100	20	19
150	150	30	19
200	200	34	24
250	250	42	27
300	300	51	27

6. Service and Maintenance

The valves do not require regular maintenance work. However, when a pipeline section is inspected, the valve may not show any leakage to the outside.

The valve should be checked for tightness and proper function at least once per year.

7. Drawing and parts list

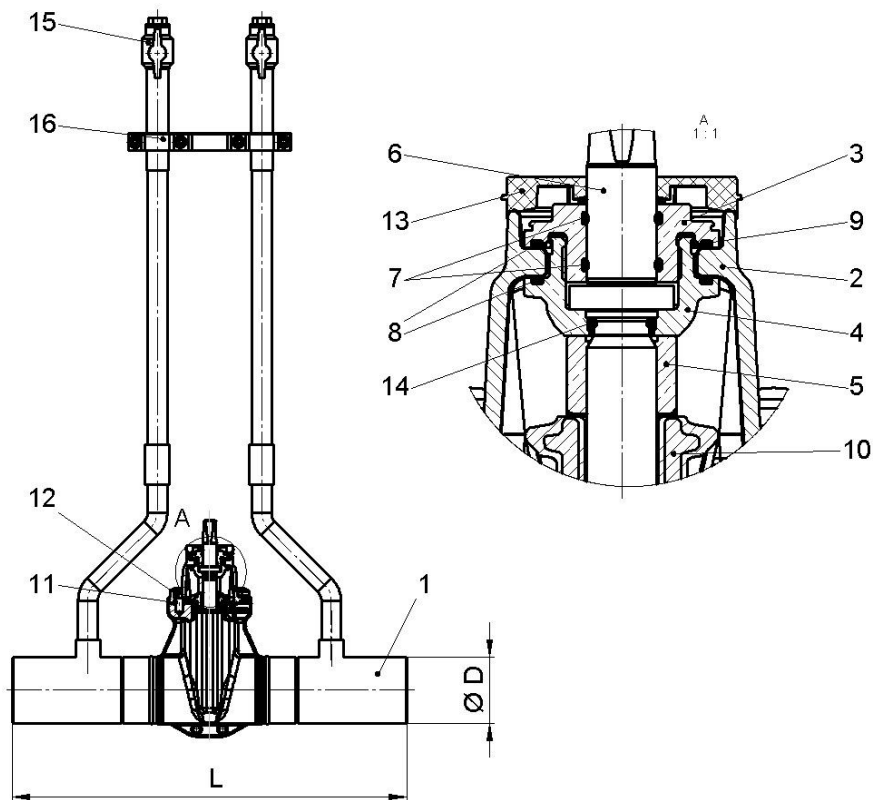

Pos	Description
1	body
2	bonnet
3	cap nut
4	clamp piece
5	stem nut
6	stem
7	o-ring
8	o-ring
9	snap ring
10	wedge
11	head gasket
12	cylinder screw
13	adapter piece
14	o-ring
15	ball valve
16	pipe clamp

Lengths

DN	L	Ø D
80	660	88,9
100	680	114,3
150	730	168,3
200	780	219,1
250	1050	273,0
300	1084	323,9

8. Diagnostics and trouble shooting

Problem	Possible cause	Remedial action
Gate valve does not close	Foreign particle on sealing face	Remove foreign particle
	Heavy deposits on the sliding surface	Clean sliding surface
Gate valve does not open	Foreign particle is jamming sealing wedge	Remove foreign particle

Leakage at the stem or seat gasket:

- Check whether the valve is completely shut.
- If so: Verify whether the valve has been shut with the full torque.
- If leakage on the valve continues: Open and shut the valve several times while under pressure.
- If the leakage on the valve continues: Repair necessary.



We would like to point out that we do not assume any liability for damages or disruption of operations resulting from non- observance of the operating manual.

The distribution and reproduction of these Operating Instructions, utilization and communication of their contents to others is authorized exclusively for the purpose of ensuring the correct installation and operation of the Düker product treated in the document. For all other purposes, distribution, reproduction and utilization of the contents, also in excerpts, is prohibited. Offenders will be held liable for the payment of damages. All rights reserved in the event of the grant of a patent, utility model or design.